



# SAINT-GOBAIN SULLY

## PRODUCTS PRESENTATION

The information contained herein is confidential. Disclosure or reproduction without prior written approval of Saint-Gobain Sully is prohibited. Duplication is not permitted.

# ATR 42/72 COCKPIT WINDOWS

## FULLY INTERCHANGEABLE



R/H

L/H

SPSATR42-5-1-0  
I/C with NP158803-2

SPSATR42-6-1-0  
I/C with NP158803-1

SPSATR42-3-2-2  
I/C with NP158862-4

SPSATR42-4-2-2  
I/C with NP158862-3

SPSATR42-1-2-2  
I/C with NP158801-4

SPSATR42-2-2-2  
I/C with NP158801-3

## Key Advantages

- Repairability
- FOD Outer Ply Crack
- Heating System
- Wiper Scratches
- Excellent Water Tightness
- Flat Exchange Program
- Warranty 24 months from Installation

# ATR 42/72 CABIN WINDOWS & WINGTIP LIGHT COVERS

## FULLY INTERCHANGEABLE

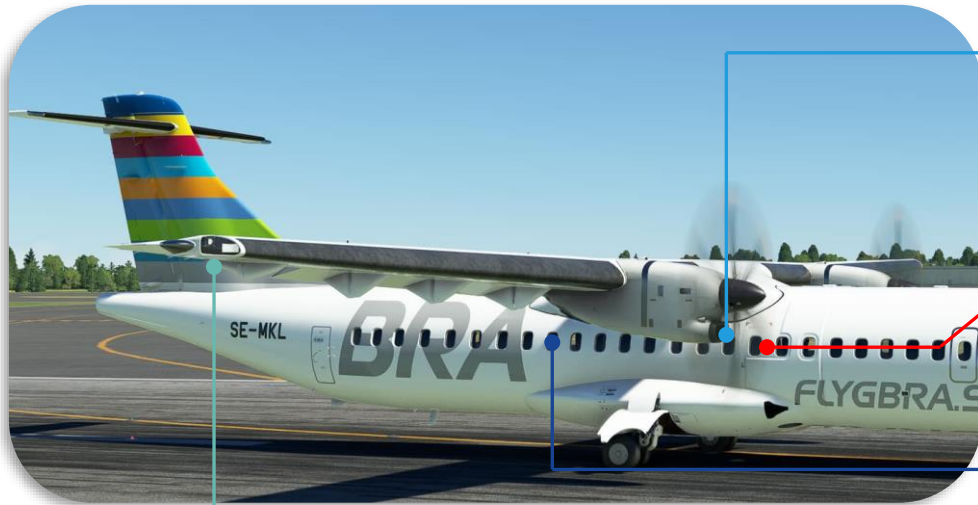

ATR42/72 - Rear Ice Impact Set Assembly  
SPSATR42-8-1-0  
*I/C with NP-158815*

ATR42/72 - Forward Ice Impact Set  
Assembly SPSATR42-9-1-0  
*I/C with NP-158814*

ATR42/72 – Cabin Window Std. Assembly  
SPSATR42-7-2-0  
*I/C with NP-158824*

ATR 72  
S5731200200900 – R/H  
S5731200200800 – L/H

ATR 42  
S5731005101300 – R/H  
S5731005101200 – L/H

# A320 FAMILY COCKPIT WINDOWS

## FULLY INTERCHANGEABLE

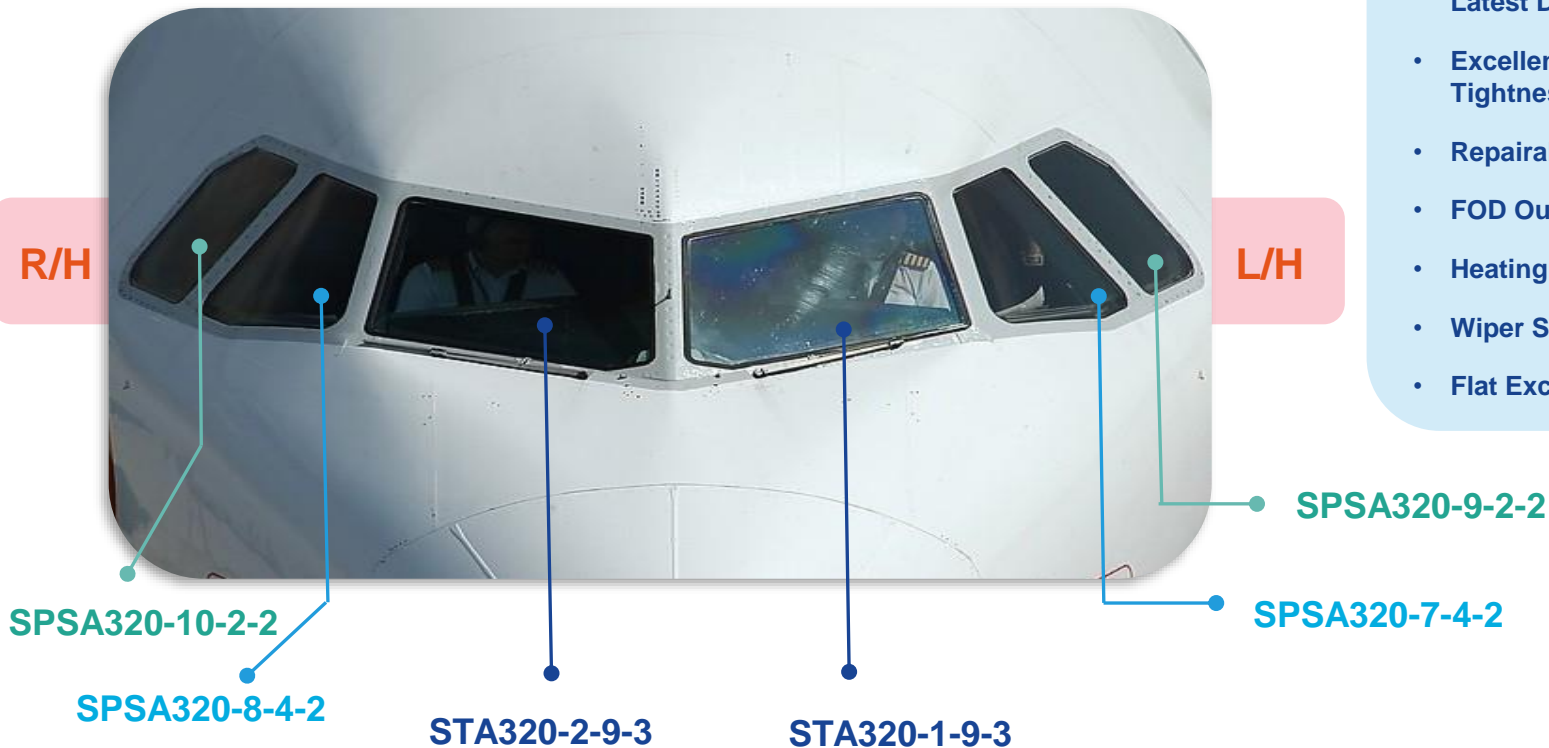

### Key Advantages

- Windshields Market Latest Design
- Excellent Water Tightness
- Repairability
- FOD Outer Ply Crack
- Heating System
- Wiper Scratches
- Flat Exchange Program

# A320 FAMILY COCKPIT WINDOWS

## WINDSHIELD INTERCHANGEABILITY (IPC Extract)

### 2. **A320** family

#### 2.1. WINDSHIELDS



- **GKN**
  - 25022/25023
  - 06282/06283
- **PPG**
  - NP165311-1/-2, -3/-4, -5/-6, -7/-8 and NP15331-1/-2
- **SGS**
  - SPSA320-1-9-3
  - SPSA320-2-9-3

# A320 FAMILY COCKPIT WINDOWS

## SLIDING WINDOWS INTERCHANGEABILITY

# A320 family



**SLIDING WINDOW**

**IPC 56-12**

Refer to §1 for details

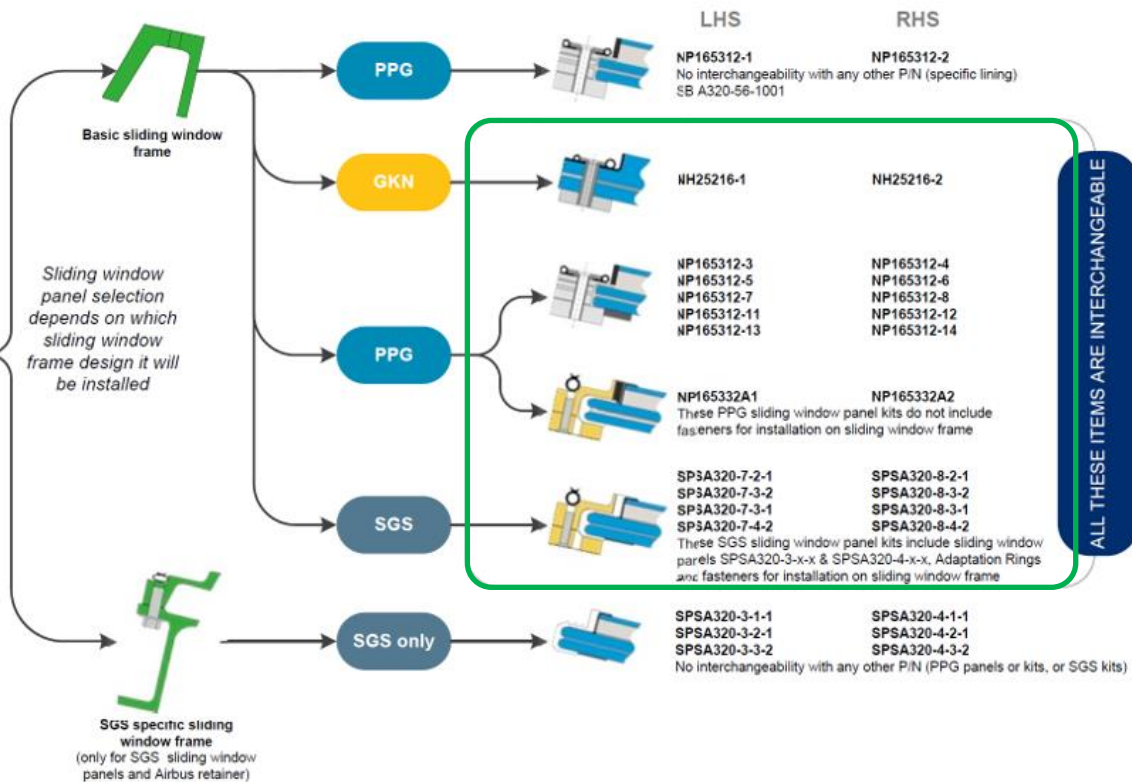
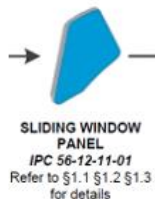

# A320 FAMILY COCKPIT WINDOWS

## FIXED SIDE WINDOW INTERCHANGEABILITY

**A320** family



**FIXED SIDE WINDOW**  
*IPC 56-11-01-02*

Refer to §2 for details

**GKN**

**PPG**

**SGS**

LHS

RHS

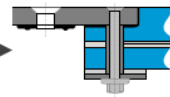

NH25216-141  
NH25216-349

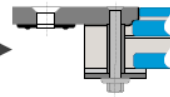

NP165313-1  
NP165313-3

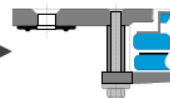

NP165333A1  
NP165333A3

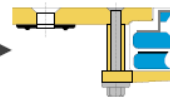

SPSA320-9-1-1  
SPSA320-9-2-2

NH25216-142  
NH25216-350

NP165313-2  
NP165313-4

NP165333A2  
NP165333A4

SPSA320-10-1-1  
SPSA320-10-2-2

ALL THESE ITEMS ARE INTERCHANGEABLE

# A330/340 COCKPIT WINDOWS

## FULLY INTERCHANGEABLE

### Key Advantages

- Repairability
- FOD Outer Ply Crack
- Heating System
- Wiper Scratches
- Excellent Water Tightness
- Flat Exchange Program

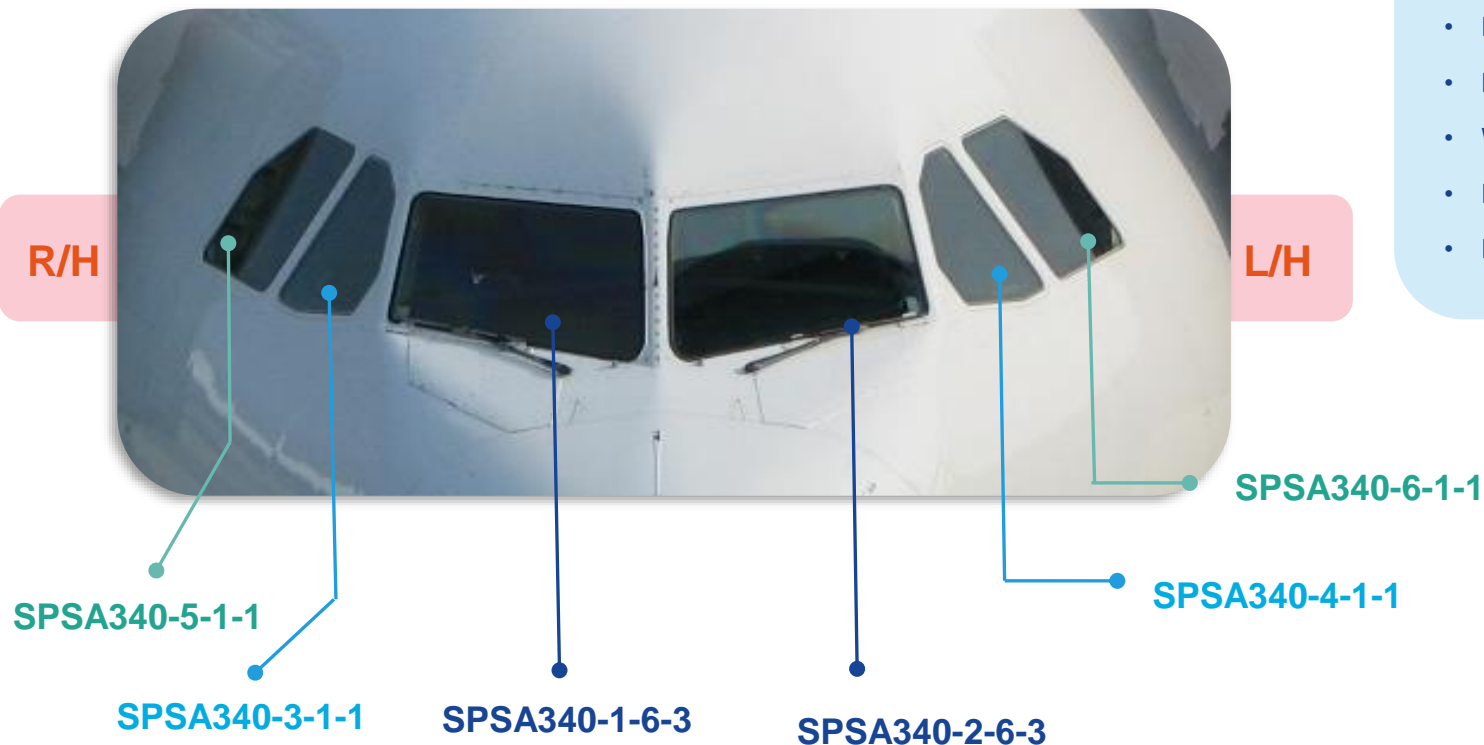



# REPAIR EXAMPLE

## A320 SLIDING SHOW

### BEFORE REPAIR

- Outer Ply Cracked due to FOD Impact



### Repair Process includes :

- Metallic Frame Inspection
- Panel Replacement
- New Seals

### AFTER REPAIR

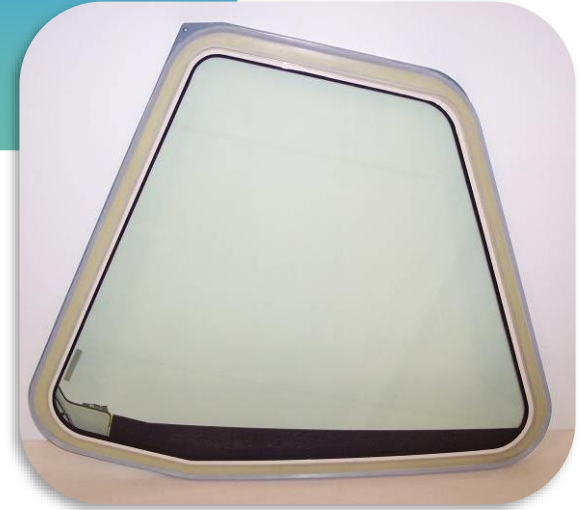

# RECENT REFERENCES

Cathay Pacific A320neo



Vistara A321neo



# RECENT REFERENCES

AirAsia A320neo



China Southern A320neo



# RECENT REFERENCES

China Airlines A320neo



Kuwait Airways A330-800neo



# RECENT REFERENCES

Swiss Air A320neo



Transavia A320neo



# Aerotechnic

**AEROTECHNIC (PTY) LTD – CAPE TOWN**

Unit 4, 3rd floor, 50 Riebeek Street 8001.

Cape Town, South Africa, 4575

**Tel:** +27 -21 421 4575

**Email:** [sales@aerotechnic-group.com](mailto:sales@aerotechnic-group.com)